

DOUBLE DIAPHRAGM PUMPS

VERDERAIR OVERVIEW

The most efficient
diaphragm pump



- ✓ Increase productivity
- ✓ Reduce operational cost
- ✓ Improve working environment

ENABLING PROGRESS.

GET IN TOUCH

With the double diaphragm pump manufacturer

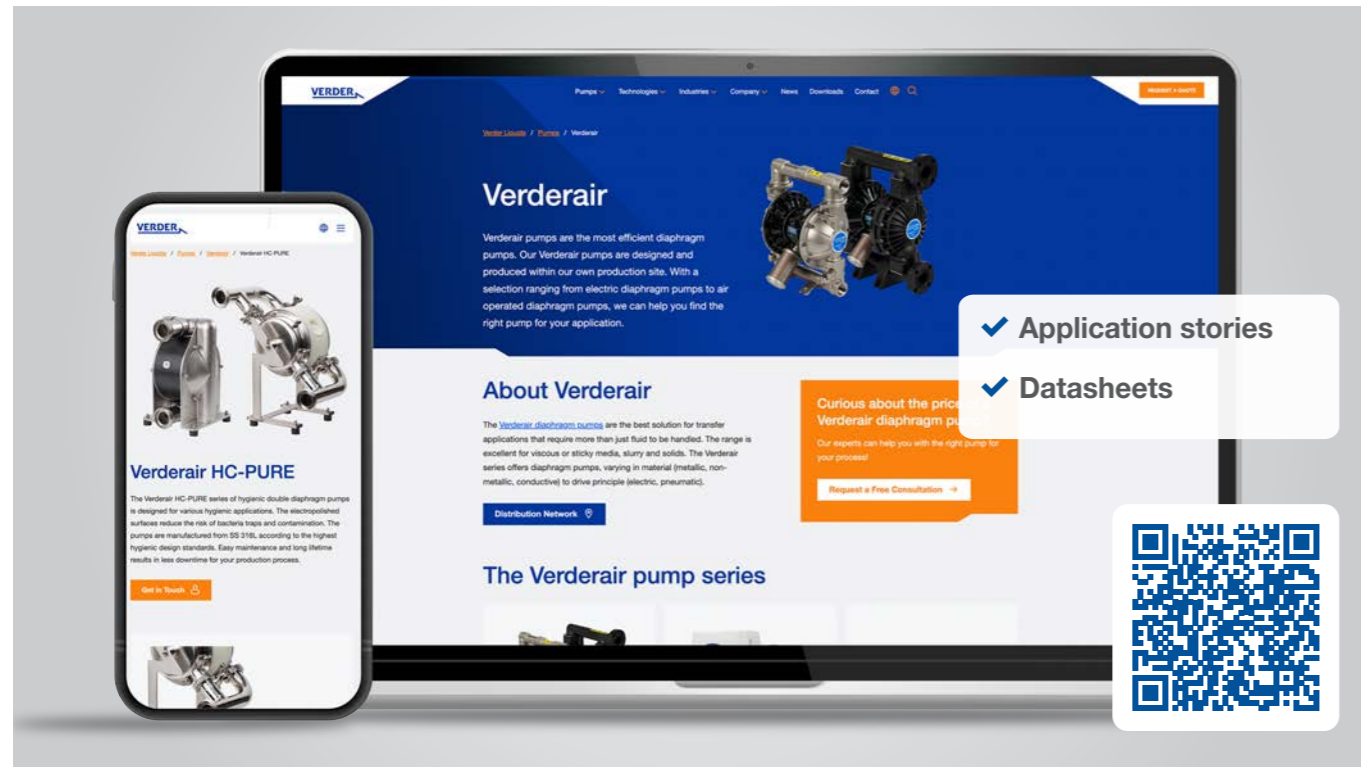

Contact VERDER

If you would like to know more about VERDERAIR pumps then please visit our website www.verderliquids.com where you will find the full breakdown of our pump range as well as application stories, latest news and technical datasheets and more.

VERDER LIQUIDS BV

Utrechtseweg 4A
3451 GG Vleuten
The Netherlands

To provide you with the best possible service VERDERAIR are supported by a distribution network that covers all five continents and is continuing to expand. Our group of distributors includes members of the VERDER GROUP and experienced independent companies. Our worldwide distribution network also help to provide our customers local support and spares availability.

VERDERAIR® is a registered trademark of the VERDER GROUP.

THE VERDER GROUP

Enabling progress



The VERDER group is a family-owned business formed over 60 years ago in the Netherlands; the group consists of a worldwide network of production and sales offices. Group companies are involved in the development and distribution of industrial and hygienic pump solutions, high-tech equipment for quality control and research & development into solid material (solids sample preparation and analytical technologies).

- 1 Company
- 27 Countries
- > 60 Years of expertise
- > 20 Manufacturing companies
- Global network
- Local distributors
- A solution for every application
- In-depth knowledge of processes and applications

For years, VERDER has led in innovation, driving our and our customers' success. Our global network of over 70 sales and manufacturing sites offers personalised sales and technical services, ensuring close customer relationships crucial for providing specific support and building lasting, trusting partnerships.

VERDER is dedicated to making a positive impact by aligning with the UN's Sustainable Development Goals (SDGs) through our Environmental, Social, and Governance (ESG) program. Our goal is to lessen our environmental footprint, enhance employee well-being, and uphold ethical practices.

Inventing to make the world a better place

We leverage our expertise in sample preparation, analytical equipment, and professional pumping to empower our customers. We enable progress by improving their operations. We contribute to safer, more efficient, and sustainable processes, products, and services. Our contributions are pivotal in securing safe food supplies, ensuring responsive healthcare, and safeguarding clean drinking water in millions of households.

As a united family, we embrace our societal responsibilities with passion and a commitment to excellence. Our collective efforts are aimed at fostering a healthier, safer, and more sustainable world for all.

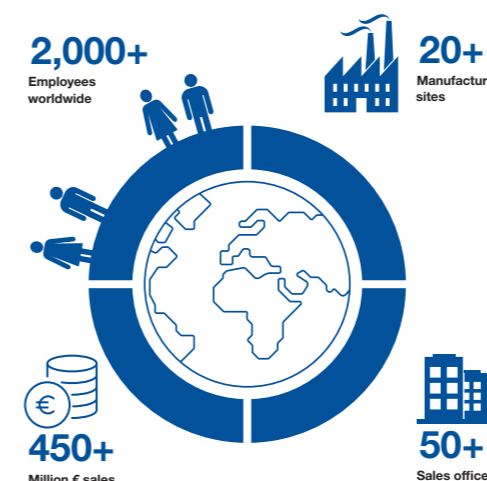

ENABLING PROGRESS.

VERDERAIR

Double diaphragm pumps



VERDERAIR is a core VERDER group product, solving pumping problems in such varied industries as: chemical manufacturing, food production, environmental remediation, chemical and processing industries, as well as general manufacturing and Original Equipment Manufacturing. VERDERAIR double diaphragm pumps are manufactured in the EU. There are series available with specified food grade certificates, solid machined heavy duty pumps, hygienic series, and electric driven double diaphragm pumps.

VERDERAIR double diaphragm pumps are the ideal solution for almost all liquids, also for very demanding applications. The series range from smaller OEM pumps to high flow industrial series. VERDERAIR double diaphragm pumps are used with a variety of fluids.

OPERATION PRINCIPLE

Double diaphragm pumps

An air operated double diaphragm pump has two diaphragms. These diaphragms are connected by a shaft in the center section. The diaphragms are working as separation wall between the air and the liquid. The air valve is located in the center section of the diaphragm pump. The air valve directs the compressed air to the back of diaphragm number one. In this way diaphragm number one moves away from the center section. This diaphragm causes a press stroke moving liquid out of the pump. At the same time diaphragm number two is performing a suction stroke.

The air behind diaphragm number two is being pushed out to the atmosphere. Atmospheric pressure pushes the liquid to the suction side. The suction ball valve is being pushed away off its seat. This allows the fluid to flow along the ball valve into the liquid chamber.

When the pressurized diaphragm number one has reached the end of its stroke, the movement of the air is switched from diaphragm number one to the back of diaphragm number two by the air valve. The compressed air pushes diaphragm number two away from the center block. Doing so, diaphragm number one is pulled toward the center block. In pump chamber number two the discharge ball valve is pushed off its seat. In pump chamber number one the opposite occurs. Upon completion of the stroke the air valve leads the air again to the back of diaphragm number one and restarts the cycle as described above.

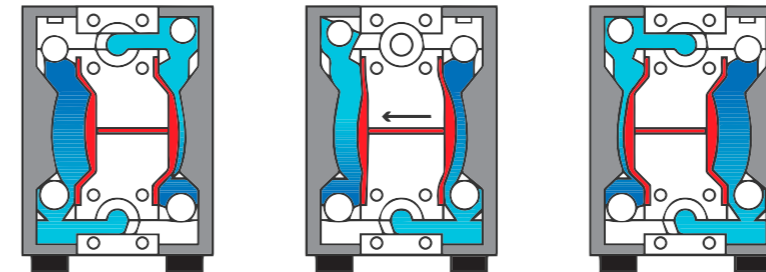

VERDERAIR performance overview



What are your benefits using a VERDERAIR pump?

Higher flow rate

Low 'pressure drop' when the liquid passes the pump chamber. Smoother flow, increased efficiency pumping the liquid. The diaphragms have a special profile which is designed for an extremely long working life.

Lower air consumption

The quick-acting air valves are very fast in changing direction. No compressed air enters the air chamber when the stroke has completed. The used compressed air is removed with almost no restrictions. The compressed air is only used to move the liquid.

Less noise

By using all of the compressed air the pump makes less noise and the risk of freezing the exhaust is reduced

THE VERDERAIR PROGRAM

An overview



VERDERAIR PURE

Top level AODD pumps

- 100% pure PTFE or UHMW PE
- Perfect pressure holding, limited vibrations
- 100% oil and grease free air valve
- Available with several safety options
- No metal wetted or external parts



VERDERAIR e-PURE

The sustainable electrically driven diaphragm pump

- Very energy efficient
- Plug and play
- Less maintenance - longer life time
- Low noise level
- Low pulsation



VERDERAIR STANDARD

The allrounder of the AODD pumps

- Wide range of available materials
- Quick acting air valve, highest efficiency
- Safe operation and easy maintenance
- Anti-ice mufflers standard on HE range
- Overmolded diaphragms for longer lifetime



EODD 2ND GENERATION & HYGIENIC

Very energy efficient and compact EODD

- Very energy efficient
- Low noise level
- Small footprint
- Easy to maintain
- Lightweight



VERDERAIR HC-PURE

Top level hygienic AODD pumps

- Best cleanability: CIP/SIP
- According to EN1935/2004 & FDA
- Electropolished
- Easy to maintain
- 100% oil and grease free air valve



VERDERAIR CONT-EX

The small AODD for OEM and demanding applications

- Compact design
- Machined out of solid UHMW PE Conductive
- 100% oil and grease free air valve
- 4 sizes available
- Cylinder valves for better suction lift available

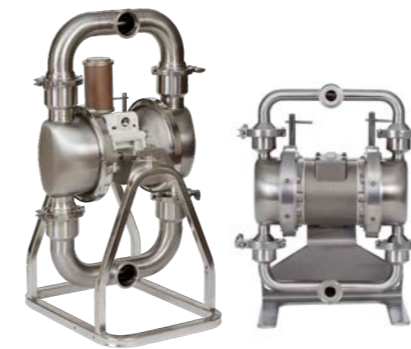

VERDERAIR HI-CLEAN

The performer for food and cosmetic applications

- According to EN1935/2004, FDA & 3A
- Strip cleaning: fast disassembly
- CIP/SIP
- DIN 11851 or Tri-Clamp connections
- 3.2µm – 0.8 µm polished surface finish



VERDERAIR EODD & HI-CLEAN EODD

The allrounder but with electrical drive

- Electrically driven
- Same liquid parts as the VA range of pumps
- Center section technology, longer diaphragm life
- Can stall against closed discharge
- Low pulsation mode

THE AIR VALVE

The heart of your double diaphragm pump

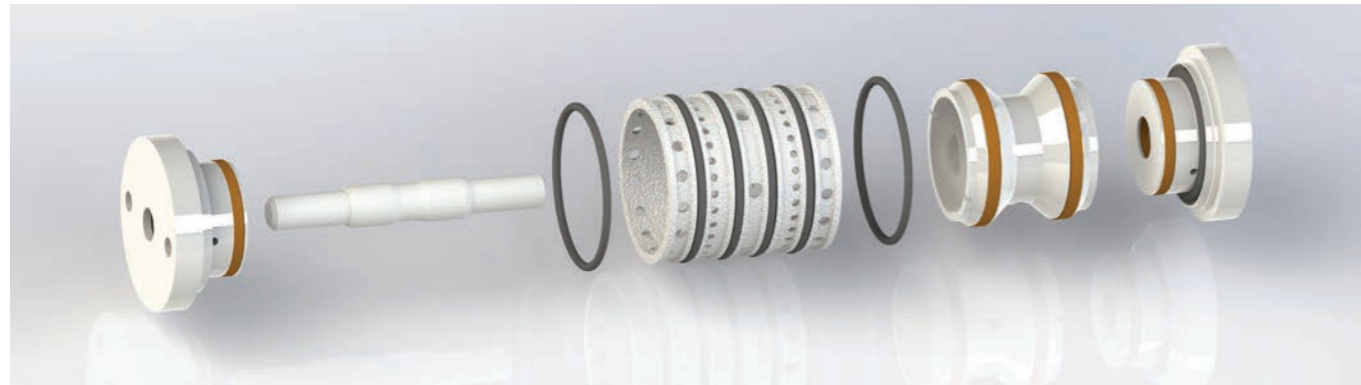

General features

- ✓ Non-stalling
- ✓ No air lubrication needed
- ✓ Easy maintenance
- ✓ No freezing

The heart of your double diaphragm pump is the air valve. Comparable with the heart of the human body, the efficiency of your diaphragm pump is depending on the quality of air valve of the pump. Sometimes your pump has to run slow and steady for a long period, sometimes you want a quick fluid transfer. With this in mind, VERDERAIR has developed 3 different kind of air valves, with their specific features, to make the best out of each air operated double diaphragm pump.

Standard Air Valve

(For VA standard and HI-CLEAN)

Cup and plate design air valve. Reliable air valve which has proven his functionality over the years.

- Built from 9 parts
- Assembly inside the center block
- Proven design



Quick Acting Air Valve

(For VA standard HE versions)

Modular cup and plate design air valve. The most efficient on the market.

- Built from 13 parts
- Externally serviceable
- The "sprinter" under the air valves



PURE Air Valve

(For VA PURE, HC-PURE & CONT-EX)

Cartridge design to work in the most severe environments.

- Cartridge design
- Assembly inside the center block
- 100% self-lubricating



MATERIALS TO CHOOSE FROM

To meet your most severe process

To meet your most severe process conditions, yet still having a trouble-free operation, VERDERAIR pumps have nine different material options for the valve seat, diaphragm & balls. The combination of these high quality materials together with the choice of different pump materials give the optimum pump selection.

Acetal Wide range of solvent resistant and withstands extreme fatigue. Good level of abrasion resistance. Electrically conductive (ATEX).



Santoprene Good resistance to abrasive and chemical fluids. Santoprene is compatible with some solvents (e.g. Acetone, MEK), caustic solutions, dilute acids and alcohols.



Teflon (PTFE) Most compatible material for chemical applications, extremely resistant to corrosion and high temperatures, very low friction coefficient, non-adhesive.



Thermoplastic polyester (Hytrel) Good performance properties at lower temperatures and good resistance to abrasive fluids. Thermoplastic polyester is often a substitute for Buna-N.



Fluorelastomers (Viton) High heat resistance. Good resistance to aggressive chemicals including acids and some solvents. (e.g. xylene and mineral spirits). Good resistance to steam as well as animal, vegetable and petroleum oils. Resists unleaded fuels.



Geolast Abrasion resistance. Approximately same chemical compatibility as Buna-N.



Polychloroprene (Neoprene) Good chemical resistance, good performance with oils and many chemicals, good temperature resistance, outstanding physical toughness, outstanding resistance to damage caused by flexing and twisting. Resistance to abrasion is approximately 30% higher than Buna.

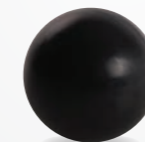

EPDM Good water and chemical resistance. Not for use with oils, greases and most solvents.



BUNA Good for petroleum-based fluids, water, oils, hydrocarbons and mild chemicals (e.g. mineral spirits).



VERDERAIR PURE

Solid machined double diaphragm pumps



Key features

- ✓ Solid machined
- ✓ 100% oil and grease free air valve
- ✓ No metal wetted or external parts
- ✓ Available with several safety options

The VERDERAIR PURE double diaphragm pump series is a robust series of double diaphragm pumps, produced from one-piece solid material. The VERDERAIR PURE is designed for heavy-duty operation, also for harsh liquids and severe process conditions, such as operating in power plants and refineries.

The VERDERAIR PURE has all the benefits of a VERDERAIR double diaphragm pump such as increased productivity through a higher flow rate and reduced operational cost because of lower air consumption. On top of that the PURE series has an extended program of accessories. Thanks to the efficient operation less maintenance is needed. Improved working environment is realized because the pump makes less noise.

The VERDERAIR PURE is available in 4 wetted part materials; each pump being made from one solid block of the purest and finest PTFE or PE UHMW and in conductive for ATEX applications.

Technical details

Max. Flow	660 l/min
Max. Pressure	7 bar
Options	ATEX



PD-P PULSATION DAMPENERS

To reduce a pulsed flow

Due to the function principle, air operated double diaphragm pumps are generating a pulsating flow. By using a VERDERAIR pulsation dampener in combination with the pump, the flow pulses will be reduced to the minimum.

The VERDERAIR pulsation dampeners are active dampeners and achieve the best possible dampening effect to create an almost flat flow.

	PD-P8	PD-P10	PD-P15	PD-P25	PD-P40	PD-P50
Connections NPT male thread or combi flanged	8 mm	10 mm	15 mm	25 mm	40 mm	50 mm

Materials

Polyethylene (PE)

Extremely abrasion resistant. Upto 7 times better than Polypropylene. Chemical resistance is compatible to Polypropylene.

Conductive Polyethylene

Similar properties to Polypropylene but conductive for ATEX applications.

Teflon (PTFE)

Widest chemical compatibility, extreme corrosion resistance, very low frictional coefficient, non adhesive, high heat resistance.

Conductive teflon

Similar properties to PTFE, but electrically conductive for ATEX applications.



VERDERAIR PURE

Accessories

To achieve even more and broader possibilities VERDER offers an extended line of accessories for the VERDERAIR PURE double diaphragm pumps.

Leak detection (LS)

The diaphragms can be monitored by the assembly of a capacitive sensor in the muffler of the pump. When a diaphragm fails the sensor will detect the presence of the liquid and generate a signal. The sensor must be connected to a controller.



Barrier System (BS)

Barrier system has double liquid chambers and diaphragms on both sides. The chamber between both diaphragms is filled with a neutral liquid and monitored by conductive and capacity sensor. When a diaphragm fails, one of the sensors will generate a signal. The sensor must be connected to a controller.



Stroke sensor (SS)

To measure the number of strokes your pump is making, you can use the option SS (stroke sensor). An inductive proximity switch is mounted in the centre part of the pump. This switch generates a pulse with every stroke of the diaphragms.

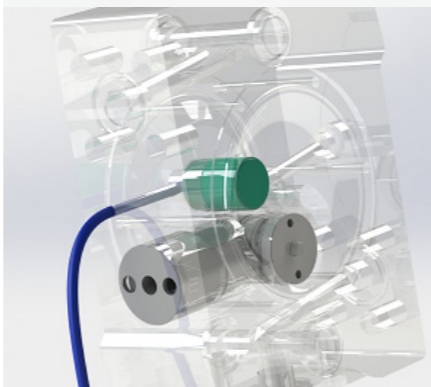

Manual draining system (DM)

To be able to drain the remaining liquid on top of the valves when the pump is stopped you can use the manual draining system. Both side housings are equipped with a bypass system and a manual operated valve.

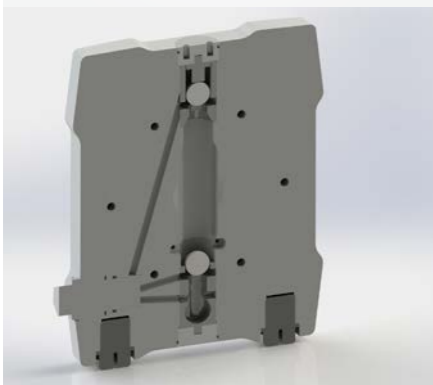

Pneumatic draining system (DP)

Pumps with option code DP are equipped with side housing with bypass system and pneumatically operated valves. By using a 4/2 electro-pneumatically valve, the draining system can be activated by an electrical signal.

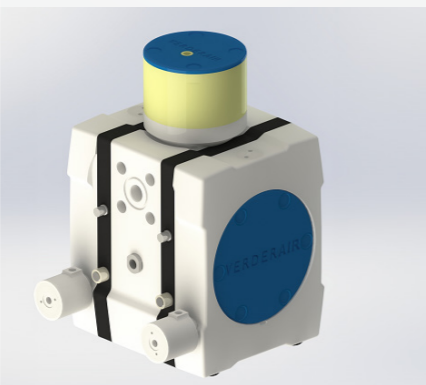

Remote operation (RE)

To control the stroke frequency of your pump a solenoid valve is added. In this setup the pump is equipped with 2 air connections in direct contact with the air side of each diaphragm.

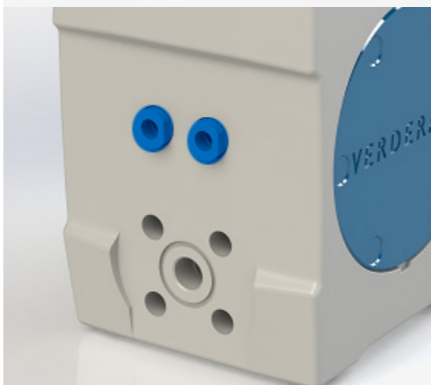

VERDERAIR e-PURE

The future of electrically driven double diaphragm pumps



The VERDERAIR e-PURE pump series works according to a horizontal fluid flow path, which gives a more energy efficient and less friction loss fluid path resulting in reduced maintenance, lower energy costs and a longer life time.

The pump housing is manufactured from solid machined PTFE or PE (UHMW). Other wetted parts are made from PEEK and SS 316L. The e-PURE ensures a sustainable solution combined with diaphragm pump advantages.

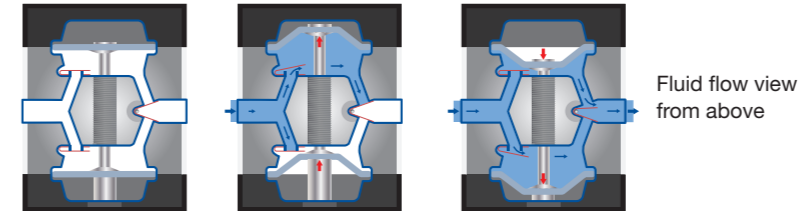

Key features

- ✓ Very energy efficient
- ✓ Plug & play
- ✓ Less maintenance
- ✓ Low noise level
- ✓ Low pulsation

Innovative design - horizontal fluid path

The electric drive ensures the reciprocating movement of the diaphragms so that the diaphragm chambers are alternately filled and pressed. This pump design utilises flapper valves instead of ball valves, a reduced number of flow bends and moving parts resulting in less friction losses.

The speed of the fluid and the energy efficiency of these pumps is therefore optimal. The direct results are reduced maintenance, lower energy costs and a longer life time. High speed low stroke technology enables low pulsation.

Technical details

Max. Flow	100 l/min
Max. Pressure	5 bar
Options	ATEX

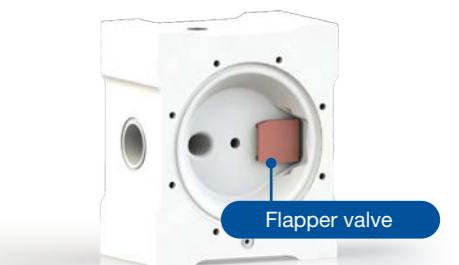

VERDERAIR HC-PURE

Hygienic durability due to perfect cleanability



Key features

- ✓ Best cleanability
- ✓ Easy to maintain
- ✓ Electropolished
- ✓ Maintenance free air valve
- ✓ Highest hygienic design principles

The Verderair HC-PURE series of hygienic double diaphragm pumps is designed for various hygienic applications. The electropolished surfaces reduce the risk of bacteria traps and contamination. The pumps are manufactured from SS 316L according to the highest hygienic design standards. Easy maintenance and a long lifetime results in less downtime for your production process. The center block is made from a solid block of PE (UHMW) or PA (Polyamide) and available in ATEX.

The Verderair HC-PURE hygienic double diaphragm pump is available in two designs: the FD series for hygienic applications at the beginning and mid stage of of the production process, and the SB series for hygienic applications at the mid and final stage of the production process.

Technical details

Max. Flow	650 l/min
Max. Pressure	7 bar
Options	ATEX



HC-PURE FD



HC-PURE SB

VERDERAIR CONT-EX

All-purpose double diaphragm pumps



The CONT-EX pump is an OEM pump for middle flows and many different applications. The pumps are also used as barrel emptying pump.

The CONT-EX series of pumps are made from a solid block of conductive UHMW-PE. This series can be used in EX environments. The pump series have a very high resistance to both abrasion and corrosion. Models available with ball and cylinder valves (for better dry suction lift).

Technical details

Max. Flow	105 l/min
Max. Pressure	7 bar



Features of the CONT-EX pumps

- ✓ Solid machined
- ✓ Made out of conductive polyethylene
- ✓ Available in 4 sizes (10, 20, 50 or 105 l/min)
- ✓ ATEX certified
- ✓ Ball valves or cylinder valves



VERDERAIR VA METALLIC

Standard solutions for various industries



Features

- ✓ Wide range of different materials available
- ✓ Quick acting air valve technology
- ✓ Safe operation and easy maintenance

The VERDERAIR VA metallic series of diaphragm pumps is used throughout industry for various media such as paints and solvents, waste water (or mixtures of water & chemicals), oil and lubricants.

In applications such as oil transfer, oil skimming and chemical plating a VERDERAIR metallic diaphragm pump is an excellent choice; as well as for filter press applications, transfer drum, tank stripping and unloading fluids, and many more.

Materials

Aluminium General purpose material. Good for solvent based coatings and inks. Resistant to mild chemicals.

Cast Iron Highly abrasion resistant. Often used in paper, waste water industry and mining.

Stainless Steel 316 Resistant to most acids, bases and solvents. Can handle halogenated hydrocarbons. Good resistance to abrasive media.

Technical details

Model	VA-20	VA-25	VA-40	VA-50	VA-80
Connections (mm)	20	25	40	50	80
Max. Flow (l/min)	61	189	443	568	1.200
Max. Pressure (bar)	7	8,6	8,4	8,4	8,6
Options	ATEX	ATEX	ATEX	ATEX	ATEX



VERDERAIR VA NON-METALLIC

Standard solutions for various industries

VERDERAIR non-metallic double diaphragm pumps are excellent pumps for use in a wide range of applications across many industries. Depending on your medium or chemicals, fluid and process specifications, the best solution is selected. Application areas are amongst others paint & lacquer and chemical fluids.

Materials

Polypropylene Has a wide chemical compatibility for general purpose applications; PP is limited temperature resistant.

Conductive Polypropylene Similar to standard Polypropylene but electrically conductive (ATEX).

PVDF (Kynar) The best choice for even the most chemically aggressive media.

Acetal Compatible with many solvent applications and can withstand extreme fatigue. Good resistance to abrasive media and is conductive for ATEX applications.

Technical details

Model	VA-08	VA-10	VA-15	VA-25	VA-40	VA-50	VA-80
Connections (mm)	8	10	15	25	40	50	80
Max. Flow (l/min)	19	25	57	189	462	757	1.059
Max. Pressure (bar)	7	7	7	8,6	8,6	8,6	7
Options	ATEX	ATEX	ATEX	ATEX	ATEX	ATEX	ATEX

Accessories for VA metallic and non-metallic pumps:

Verder offers an extended line of accessories for double diaphragm pumps.

Stroke Sensor

To measure the number of strokes

Remote Operated Pump

To control the stroke frequency

Leak Detection

Capacitive sensor to detect diaphragm failure

Where the non-metallic VA stands out

VERDERAIR VA offers four non-metallic materials to choose from. Conductive Polypropylene and Acetal can be used in ATEX rated zones. PVDF is the best choice for even the most chemically aggressive media.



VERDERAIR VA FLAPPER

The rugged high performer



Key features

- ✓ High performance
- ✓ Durable flapper valves
- ✓ Externally serviceable air valve
- ✓ Can run-dry without damage
- ✓ Dry self-priming

The VA flapper double diaphragm pumps are excellent pumps for use in mines, sumps or in-plant. With their flapper valves they can handle big particles up to 46 mm. The powder-coated finish protects the pump in harsh environments.

Technical details

Max. Flow	570 l/min
Max. Pressure	7 bar
Options	ATEX

VERDERAIR EODD 2ND GENERATION

Electrically driven double diaphragm pumps

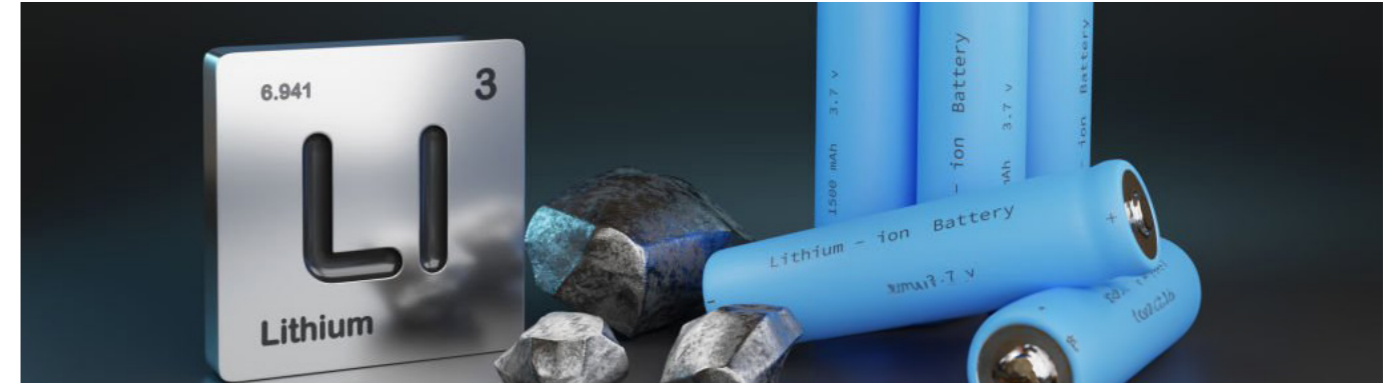

The 2nd generation of VERDERAIR EODD pumps combines all advantages of an AODD with the energy efficiency of an electrically driven pump. It's designed to be quieter, lighter, more reliable, and easier to maintain.

The 2nd generation of the VERDERAIR EODD represents a significant advancement in electric pump technology. Its innovative electric motor is designed to cut running expenses and ensure continuous operation in production environments. Suitable for a wide range of fluid processes, it seamlessly integrates as a substitute for current pump systems.

Technical details

Max. Flow	454 l/min
Max. Pressure	6,9 bar
Options	ATEX



Where the EODD 2ND Generation stands out

- ✓ Very energy efficient
- ✓ Lightweight
- ✓ Quiet operation
- ✓ Reliable
- ✓ Low noise level



VERDERAIR HI-CLEAN

Hygienic double diaphragm pumps



Key features

- ✓ According to EN1935/2004, FDA & 3A
- ✓ Strip cleaning: Fast disassemble
- ✓ CIP/SIP

The VERDERAIR HI-CLEAN pumps are designed for operation in hygienic, cosmetic and food processing applications, such as fruit syrups and concentrates, sauces and cosmetic creams. They are available with DIN 11851 or Tri-Clamp connections and are easy to clean manually (strip cleaning).

HI-CLEAN FD Series

The VERDERAIR HI-CLEAN FD range has a surface finish $Ra < 3.2 \mu m$ for handling liquids in the beginning of the process.

HI-CLEAN SB & SF Series

The SB and SF range are suitable for handling liquids in the final hygienic production stage. They have a surface finish of $Ra < 0.8 \mu m$. The SB and SF are not only easy to strip clean but are also CIP and SIP cleanable.

Technical details

Model	VA-H20	VA-H25	VA-H40	VA-H50
Connections (DIN11851 or Tri-clamp)	25 mm	40 mm	50 mm	65 mm*
Max. Flow	870 l/min			
Max. Pressure	8 bar			

* only for FD series. For SB and SF series 40, 50 or 80 mm are available



VERDERAIR HI-CLEAN

Hygienic double diaphragm pumps

HI-CLEAN SP Series

The SP range is a 1 : 2.5 piston pump range. This range is especially suitable to pump viscous media from standard drums of 200 litre, or cube containers from 1000 litre, to feed the production process.

Technical details

Model	VA-H25
Discharge connection Tri-clamp*	25 mm

* only for FD series. For SB and SF series 40, 50 or 80 mm are available

Materials

Stainless Steel 316, 3,2 μm surface finish For use in food-grade applications (used in the FD and SP series).

Stainless Steel 316, 0,8 μm surface finish For use in high grade hygienic applications (used in SB and SF series)



HI-CLEAN Certificates



VERDERAIR EODD/HI-CLEAN EODD

Electrically driven double diaphragm pumps



The VERDERAIR EODD pumps (electrically driven double diaphragm pumps) are a very energy-efficient pump solution. The pumps are ideal for applications that require low pulsation and a smooth flow. The pumps are available in metallic and non-metallic materials, to be tailored for applications demanding resistance to aggressive chemicals and abrasive fluids.

The patented "air cushion" system of the EODD series, makes it possible to run the pump against a close discharge, similar to the AODD series, without the need of an overpressure protection valve. In addition the pump can run in "low pulsation mode" so there is no need to use pulsation dampeners. The EODD pump range is available in an industrial and in a hygienic model; both in 1" or 2" execution.

An EODD pump is a very energy-efficient solution. It reduces energy consumption up to 5 times compared to an AODD pump.

Accessories

- Integrated air cushion regulator
- Leak sensor

Technical details

Max. Flow	830 l/min
Max. Pressure	7 bar
Option	ATEX



VA SPECIAL DIAPHRAGM PUMPS

High pressure, drum and split manifold



Besides our 4 standard series of double diaphragm pumps the VERDERAIR range includes 3 special pump models for specific applications relevant in many industries and application areas.

VERDERAIR VA High Pressure Diaphragm Pumps

Double diaphragm pumps have a maximum air pressure rating of 8.4 bar. VERDERAIR offer a series of high pressure pumps (up to 17 bar liquid pressure) with the same benefits and features as the reliable VA series of pumps.

Max. Flow	300 l/min
Max. Pressure	17,2 bar



VERDERAIR VA Drum Pumps

For the emptying of chemicals from small barrels, containers, canisters and drums (approx. 200 l), a double diaphragm drum pump is a very good alternative for a conventional rod drum pump. Pumps are delivered with standard suction tube in several materials.

Max. Flow	61 l/min
Max. Pressure	7 bar



VERDERAIR Diaphragm Pump with Split Manifold

For the pumping of two liquids with one pump or for mixing two liquids with a 50-50 ratio.

Max. Flow	2 x 30 l/min
Max. Pressure	7 bar



PD-S PULSATION DAMPENERS

To reduce a pulsed flow



- ✓ **Less vibration in the installation**
- ✓ **Smoother flow**
- ✓ **Better accuracy of instrumentation in the discharge line**
- ✓ **Less maintenance cost of the pipework**

Air operated double diaphragm pumps have a pulsating flow. This will lead to vibrations and pipeline losses due to the pressure changes in the discharge pipeline. In processes where pulsation in the fluid stream needs to be minimized, the VERDERAIR PD-S dampeners can be used.

The VERDERAIR pulsation dampeners are active dampeners and achieve the best possible dampening effect to create an almost flat flow. The technology is based on the VERDERAIR PURE technology.

Materials

Fluid section:

- Aluminium
- Sainless steel
- Conductive PE
- UHMW PE

Air section:

- Polyamide
- Conductive PE

Technical details

Model	PD-S10	PD-S15	PD-S25	PD-S40	PD-S50	PD-S80
Connections BSP or NPT female thread	10 mm	15 mm	25 mm	40 mm	50 mm	80 mm



VERDERAIR AIR CONTROL PRO

For controlled flow regulation

To have an optimum use and life-time of your AODD pump, VERDERAIR has developed the AIR CONTROL PRO. This is a range of accessories to help you to regulate the flow of your AODD and to protect the air valve and the diaphragms against early failure. The different accessories can be used individually or assembled together as one unit.



Filter - Regulator

With semi automatic drain. The regulator will keep the compressed air pressure supply to your pump on a constant set pressure.



Throttle Valve

By using this throttling valve in combination with a pressure regulator the pump can be regulated on even low flow rates by the volume (=flow) of compressed air.



Soft Start Valve

This valve gives the pump the time to start up slowly and will increase the life time of your diaphragms.



ON-OFF Valve

Manual or electrically operated.



Flow Stop Valve

This valve will stop the air-flow to your pump when the pump is running without liquid.



VERDERAIR SPARE PARTS KITS

To keep your process running



Key features

- ✓ Complete kits available
- ✓ Avoid downtime
- ✓ Simplified stock-management

The Verderair pump was engineered to create long service life. However, regardless of the high quality standard, some parts are prone to wear and will need to be replaced over time.

To ensure a minimum disruption to your production process, we advise you to keep the necessary spares in stock at your premises. In case of emergencies Verderair can deliver right away from stock for most parts and our delivery service ensures a fast delivery. So your production process can be up and running quick again.

Verderair spare parts kits are composed of diaphragms, valve seats, valve balls and o-rings. For each model and each material choice a spare parts kit is available. Complete air valve kits are also available.



QUICK DISTRIBUTION

From Groningen, The Netherlands



We have set up a 10,000 m² logistics center in Groningen, The Netherlands, aimed to centralize the distribution of Verder Pumps in Europe. This ensures quick distribution of our pumps; In Europe even with “next day delivery” and to customers worldwide.

More than 2.000 VERDERAIR pumps and the necessary spares are available in the LCG to be shipped overnight.

To ensure a minimum disruption to your production process, we advise you to keep the necessary spares in stock.

Advantages to the Logistics Center

- ✓ Overnight shipping
- ✓ 2000+ pumps in stock
- ✓ Spare parts kits in stock



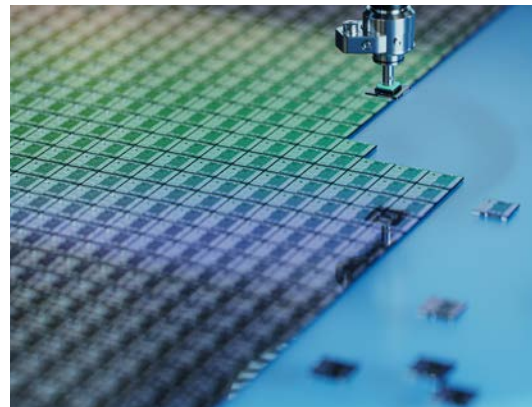

VERDER LIQUIDS

The leading pump manufacturer

VERDER LIQUIDS BV
Utrechtseweg 4A
3451 GG Vleuten
The Netherlands

MAIL info@verderliquids.com
WEB www.verderliquids.com

VERDER
passion for pumps

Austria, Belgium, Bulgaria, China, Croatia, Czech Republic, France, Germany, Hungary, India, Italy, The Netherlands, Poland, Republic Of Korea, Romania, Serbia, Slovakia, South Africa, Spain, Switzerland, United Kingdom and United States of America.